



## Low-Profile Carrying Arms



PROUDLY  
MADE IN USA



## SPL 8 LO-PRO

- ✓ All Steel Hydraulic Lines - Extended Life - No Maintenance
- ✓ The highest lifting height on the market at 83" with options for 12ft ceiling available
- ✓ Maximum stability with 3/4" steel base plate and 1/4" solid steel columns top to bottom
- ✓ High performance power unit with adjustable lowering speed through a single control lever
- ✓ Overhead shut off bar protects the car and protects against over-pressurization of the hydraulic components for longer life
- ✓ Mechanical locks provide secure locking for added safety
- ✓ Nussbaum manufactured cylinders are more ergonomic and longer lasting
- ✓ Galvanized cylinder covers provide additional safety and a clean appearance
- ✓ True asymmetric design which maximizes drive through clearance with the smallest footprint in the market and allows for optimal door clearance for easy access to the vehicle's interior

"We chose the SPL lifts for a few reasons: Reliability, Pricing and Serviceability. I recommend Nussbaum for any shop, any size and anywhere in the country."

**- Robert Radillo**  
Service Manager,  
McKenney Chevrolet  
Lowell, NC

**MORE LIFTS - LESS SPACE = MORE PROFITS**



The SPL 8 LO-PRO is a hydraulic asymmetric two post lift with a lifting capacity of 8,000 pounds and low profile arms that are best in the industry. Our low profile arms are specially designed to reach under the lowest of chassis. This lift will allow you to expand your service offerings.

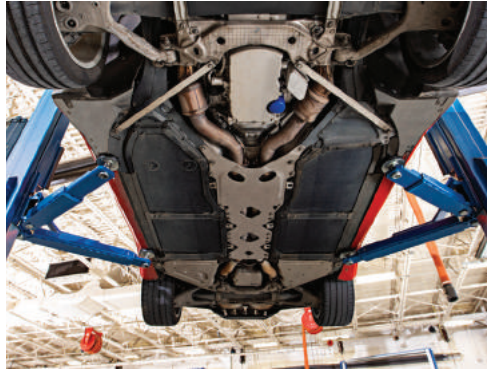

SPL 8 LO-PRO is an asymmetric lift with low profile carrying arms



First in class door protector and a powerful, yet sleek arm design



The low profile carrying arms allow you to pick up a wide range of lowered chassis.

### Low-Profile Arms

Setting industry standards, not only is the pad an amazing 3" low, so is the entire last stage of the arm. This enables access to more inboard pick up points (i.e. Audi).

## SPL LO-PRO FEATURES

- Narrow setting of 124" allows most efficient use of bay space in the industry without losing drive through width
- Highest lifting height in the industry at 83"
- Fast lifting and lowering times
- Variable lowering speed with manual control lever
- Single point release security locks
- Hard-chrome extends cylinder life
- Protective cylinder covers provide safer operation and clean appearance
- True asymmetric design for improved vehicle spotting & lifting, not a converted symmetrical lift like others in the market
- Wide range of pick up pads & adapters

### ACCESSORIES / OPTIONS

- Truck adapters to fit different vehicles' frames
- Utility box for a quick connection to air and electricity
- Electrical options with 3 phase motor

Technical Data	SPL 8 LO-PRO	SPL 8 LO-PRO XL
Lifting Capacity (lbs)	8,000	8,000
Lifting Time Approx. (sec)	37	41*
Lifting Height (in)	73.5"	83"*
Low Clearance (in)	3"	3"
Overall Height (in)	143"	160"*
Inside Height (in)	139.2"	155.5"*
Rear Arms Extension (in) min - max	33" - 54.3"	39.5" - 59"
Front Arms Extension (in) min - max	23.2" - 34"	21.5" - 43.5"
Overall Width (in) min	124"	124"
Outside Column Width (in) min	120"	120"
Inside Column Width (in) min	105"	105"
Drive Through Inside Width (in) min	94.75"	94.75"
Power Supply (V)	208/230 / 1ph (std)	208/230 / 1ph (std)

\*Pertains to XL models only.

Note: All technical data is subject to change.

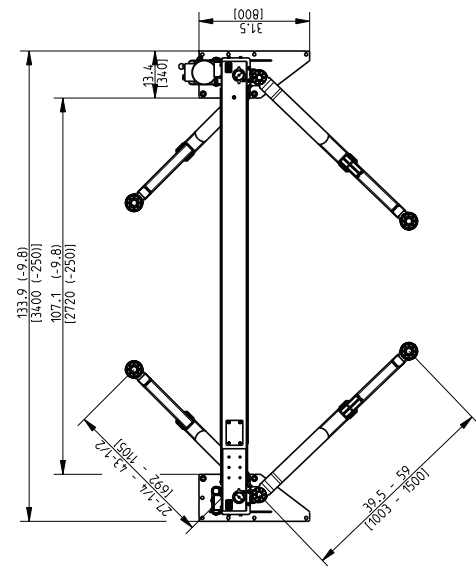

**PROUDLY**  
**MADE IN USA**

